

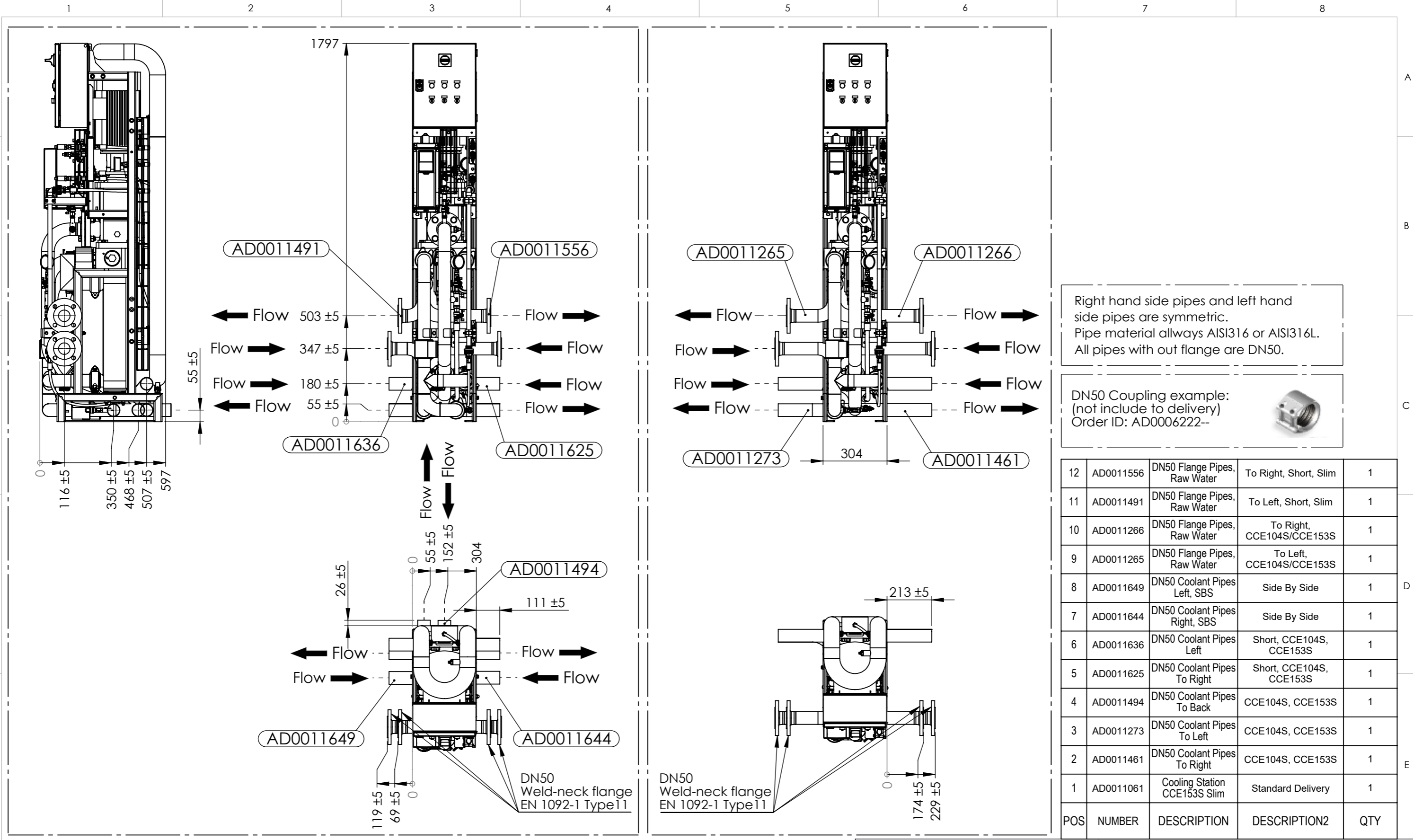

This document must not be copied without our written permission, and the contents thereof must not be imparted to a third party nor be used for any unauthorized purpose. Contravention will be prosecuted. - Adwatec oy



Right hand side pipes and left hand side pipes are symmetric.
Pipe material allways AISI316 or AISI316L.
All pipes with out flange are DN50.

DN50 Coupling example:
(not include to delivery)
Order ID: AD0006222--



12	AD0011556	DN50 Flange Pipes, Raw Water	To Right, Short, Slim	1
11	AD0011491	DN50 Flange Pipes, Raw Water	To Left, Short, Slim	1
10	AD0011266	DN50 Flange Pipes, Raw Water	To Right, CCE104S/CCE153S	1
9	AD0011265	DN50 Flange Pipes, Raw Water	To Left, CCE104S/CCE153S	1
8	AD0011649	DN50 Coolant Pipes Left, SBS	Side By Side	1
7	AD0011644	DN50 Coolant Pipes Right, SBS	Side By Side	1
6	AD0011636	DN50 Coolant Pipes Left	Short, CCE104S, CCE153S	1
5	AD0011625	DN50 Coolant Pipes To Right	Short, CCE104S, CCE153S	1
4	AD0011494	DN50 Coolant Pipes To Back	CCE104S, CCE153S	1
3	AD0011273	DN50 Coolant Pipes To Left	CCE104S, CCE153S	1
2	AD0011461	DN50 Coolant Pipes To Right	CCE104S, CCE153S	1
1	AD0011061	Cooling Station CCE153S Slim	Standard Delivery	1
POS	NUMBER	DESCRIPTION	DESCRIPTION2	QTY

MATERIAL: Material <not specified>		DIMENSIONS:	
SURFACE TREATMENT:			
Sheet metal parts only			
THICKNESS: mm	K-FACTOR:	BEND RADIUS: mm	PRODUCT CODE:
DRAWN JH	25.01.2024		CCE104S/CCE153S Pipe Modules Std HX and Full SS HX
APPROVED JH	01.02.2024		
WEIGHT 305.67 kg	SCALE 1:17	SIZE A3	DRAWING NO. AD0011230
GENERAL TOLERANCE	PROJECTION		REV. -
		www.adwatec.com	PAGE 1 / 2
ERP ITEM NO:	PROJECT:		

Pvm / Date	Suunnittelija / Designed	Muutos / Change
1	2	3

This document must not be copied without our written permission, and the contents thereof must not be imparted to a third party nor be used for any unauthorized purpose. Contravention will be prosecuted. Adwatec oy

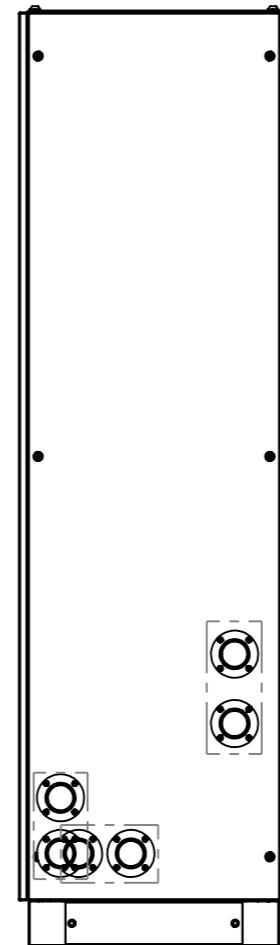
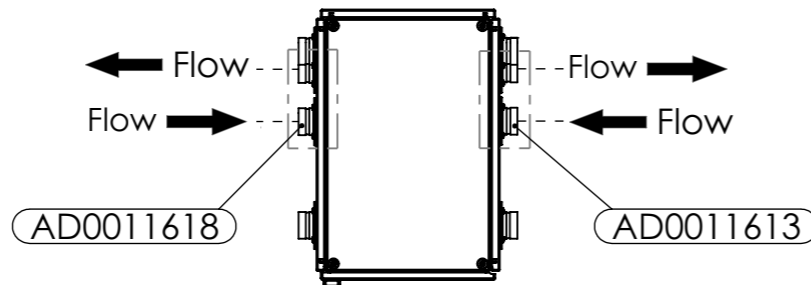
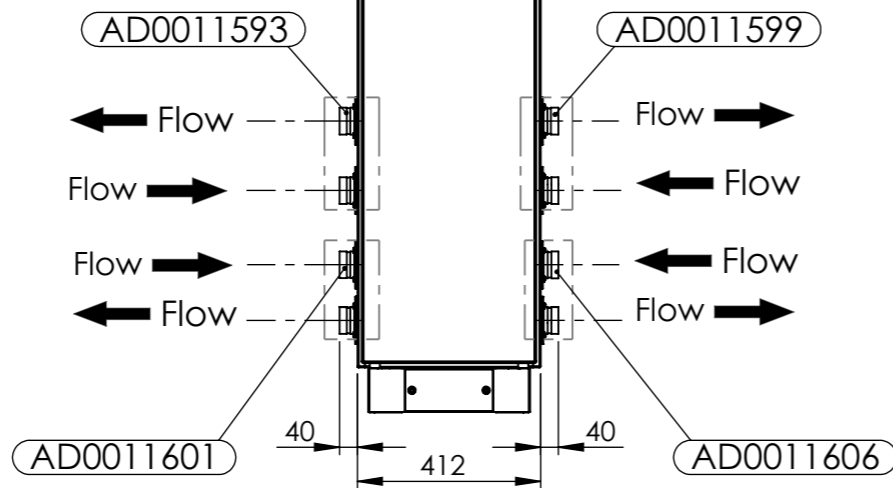
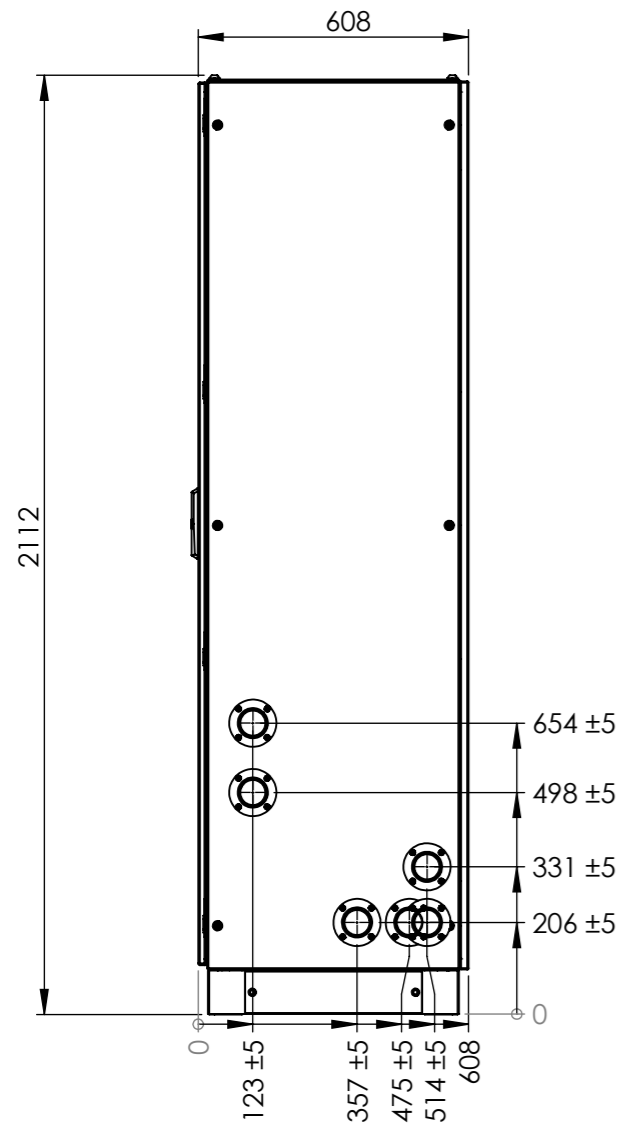

Right hand side grooved pipes and left hand side grooved pipes are symmetric. Pipe material allways AISI316 or AISI316L.

There are different kind of interface modules that you can order from Adwatec, EN Flanged, Jis Flanged etc. Interface modules contains suitable interface pipes and couplings. Example EN 1092-1 TYPE 11B flanged interface module AD0011667-- :

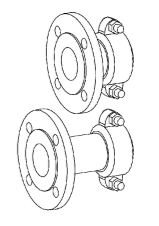

Coupling example, Quickvic Style 177N Flexible Coupling: (not included to delivery) Order ID: AD0010751--

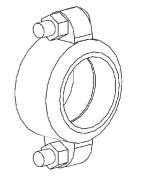

Pipes with DN50 interface on sheet1 can also be used with cabinet.

POS	NUMBER	DESCRIPTION	DESCRIPTION2	QTY
8	AD0009839	Rittal VX 400x2000x600	With Side Walls And Plinth	1
7	AD0011599	DN50 Grooved Pipes, Raw Water	To Right, CCE104S/CCE153S	1
6	AD0011593	DN50 Grooved Pipes, Raw Water	To Left, CCE104S/CCE153S	1
5	AD0011618	DN50 Coolant Pipes Left, SBS	Side By Side, Grooved	1
4	AD0011613	DN50 Coolant Pipes Right, SBS	Side By Side, Grooved	1
3	AD0011601	DN50 Coolant Pipes Left	Grooved, CCE104S, CCE153S	1
2	AD0011606	DN50 Coolant Pipes To Right	Grooved, CCE104S, CCE153S	1
1	AD0011061	Cooling Station CCE153S Slim	Standard Delivery	1

MATERIAL: Material <not specified>		DIMENSIONS:	
SURFACE TREATMENT:			
Sheet metal parts only			
THICKNESS: mm	K-FACTOR:	BEND RADIUS: mm	PRODUCT CODE:
DRAWN JH		25.01.2024	CCC104S/CCC153S Pipe Modules Std HX and Full SS HX
APPROVED JH		01.02.2024	
WEIGHT 305.67 kg	SCALE 1:17	SIZE A3	DRAWING NO. AD0011230
GENERAL TOLERANCE	PROJECTION		REV. -
		www.adwatec.com	PAGE 2 / 2
	ERP ITEM NO:		PROJECT:

Pvm / Date	Suunnittelija / Designed	Muutos / Change
1	2	3